

# MS2170

Mariner Kit for use with HP Compaq dc7900 Small Form Factor PC (Horizontal mount)



The HP Compaq dc7900 Small Form Factor (SFF) PC is marine type-approved by all of the major international marine Classification Societies when it is installed in conjunction with our Mariner Kit MS2170.

The MS2170 Mariner Kit affords protection against the effects of vibration and shock experienced in the offshore marine environment and has been type-tested against IACS Unified Requirement E10 and the relevant sections of IEC60945 (see below right for test details).

This type-approved combination of hardware and Mariner Kit can be used as the platform for your critical navigation, control, loading and general purpose applications (please check individual type-approval certificates for any restrictions).

**“Steer the right course  
with Mariner Systems”**



## WHAT IS SO SPECIAL ABOUT THE HP COMPAQ DC7900 SFF PC?

- ◆ Provides all the benefits of a full-size enterprise PC in a sleek, space-saving design without sacrificing speed, power, or serviceability
- ◆ Only two-thirds the size of a conventional desktop PC
- ◆ The dc7900 has been engineered for the specific needs of business computing
- ◆ Lengthy lifecycle (approx 15 months) and stable hardware and software images
- ◆ Energy efficient solution that helps lower electricity consumption and operating costs by utilizing improved power saving technology such as 85% efficient power supplies and power management solutions
- ◆ The dc7900 meets or exceeds most worldwide environmental PC standards – EPEAT Gold registered and ENERGY STAR® qualified
- ◆ Tool-less serviceability features for easier upgrades and repairs
- ◆ Built around the Intel® Q45 Express chipset and the latest Intel® Core™ 2 Quad and Intel® Core™ 2 Duo processors to provide the performance you expect from a commercial class PC
- ◆ Integrated Intel® Graphics Media Accelerator 4500 delivers exceptional graphics performance for all essential and multimedia requirements
- ◆ One low-profile PCI slot; Two low-profile PCI Express x16 slots; One low-profile PCI Express x1 slot
- ◆ Two front and six rear USB 2.0 ports; One DisplayPort
- ◆ Worldwide product availability and HP Global Services helps keep corporate costs low and provide consistency across regions and technologies
- ◆ Three-year limited warranty on parts and labour as standard

This Mariner system is type-tested against the consolidated, ‘worst-case’ requirements of all the major international marine Classification Societies:

**ABS, BV, CCS, DNV, GL, KR, LR, NKK, PRS, RINA**

Type-tests included on the test programme are as follows:

- > Vibration, Shock, Static and Dynamic Inclination
- > Dry & Damp Heat, Low Temperature
- > Acoustic Noise, Compass Safe Distance
- > High Voltage, Power Supply Variation & Power Supply Failure
- > Conducted LF & RF, Electromagnetic Field
- > Radiated & Conducted Emissions, Electrostatic Discharge
- > Insulation Resistance, Burst / Fast Transients
- > Surge Immunity, Access to Dangerous Voltages

# MS2170

Mariner Kit for use with HP Compaq dc7900  
Small Form Factor PC (Horizontal mount)

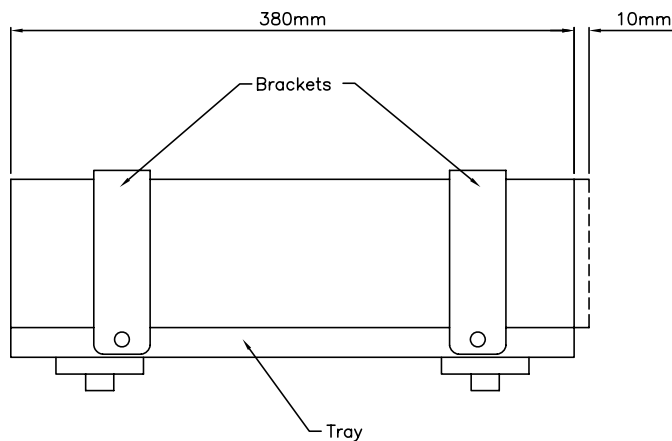
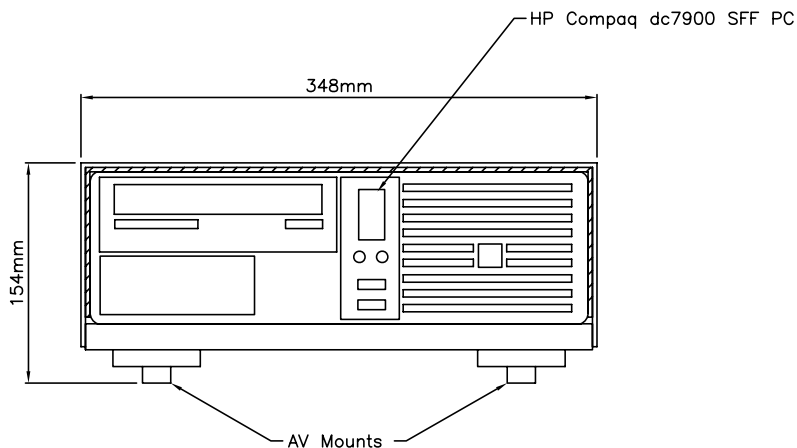

**Mariner Systems (UK) Limited**  
Oaklands Park • Wokingham • Berkshire • RG41 2FD • United Kingdom  
Telephone: +44 (0) 118 979 6020 • Facsimile: +44 (0) 118 979 6021  
sales@marinersystems.com • www.marinersystems.com

## OPERATING GUIDELINES

Although all our equipment is tested against extreme environmental conditions for the purposes of marine type-approval, installation should take into account the following guidelines:

- > Keep the computer away from excessive moisture, direct moisture and the extremes of heat and cold and, wherever possible, ensure that the unit is within the manufacturer's specified operating/non-operating ranges:

	Operating	Non-Operating
<b>Temperature</b>	+10° to +35°C (+50° to +95°F)	-30° to +60°C (-22° to +140°F)
<b>Humidity</b>	10% to 90% (non-condensing)	5% to 95% (non-condensing)

- > Leave at least 10.2 cm (4-inch) clearance on all vented sides of the computer to permit the required airflow
- > Never restrict airflow into the computer by blocking any vents or air intakes
- > Occasionally clean the air vents on the front, back and any other vented side of the computer as lint, dust and other foreign matter can block the vents and limit the airflow
- > If the computer is to be operated within a separate enclosure, intake and exhaust ventilation must be provided on the enclosure, and the same operating guidelines listed above will still apply

By following these guidelines you will maximise the life of your equipment and minimise service costs.

## STATISTICS

<b>Overall Fitted Dimensions</b>	348mm (w) x 154mm (h) x 390mm (d)
<b>Weight (Mariner Kit only)</b>	Approx 2.2 kg
<b>Weight (including hardware)</b>	Approx 11 kg
<b>Chipset</b>	Intel® Q45 Express
<b>Processor</b>	Intel® Core™ 2 Quad Q8200 / Q9400 (2.33 to 2.66 GHz, 4 to 6 MB L2 cache, 1333 MHz FSB); Intel® Core™ 2 Duo E7200 / E7300 / E8300 / E8400 / E8500 / E8600 (2.53 to 3.33 GHz, 3 to 6 MB L2 cache, 1066 to 1333 MHz FSB); Intel® Pentium® E2200 / E2220 / E5200 (2.20 to 2.50 GHz, 1 to 2 MB L2 cache, 800 MHz FSB); Intel® Celeron™ 440 (2.00 GHz, 512 KB L2 cache, 800 MHz FSB)
<b>Memory</b>	1 to 8 GB DDR2 PC2-6400 Non-ECC
<b>Hard Drive</b>	80 to 500 GB Serial ATA 3.0 GB/s (7200 rpm)
<b>Keyboard</b>	HP Standard (PS/2 or USB)
<b>Mouse</b>	HP 2-Button Scroll (PS/2 or USB); HP 2-Button Optical Scroll (PS/2)
<b>Network Card</b>	Integrated Intel® 82567LM Gigabit Ethernet
<b>Graphics</b>	Intel® Media Accelerator 4500 Graphics (integrated with Intel® Q45 Express chipset)
<b>Optical Storage</b>	HP SATA DVD-ROM; HP SATA SuperMulti LightScribe DVD Writer
<b>Audio</b>	Integrated HD audio with ADI 1884 codec
<b>Operating System</b>	Genuine Windows® Vista Business 32; Genuine Windows® Vista Business 64; Genuine Windows® Vista Home Basic 32; Genuine Windows® Vista Ultimate 32; Genuine Windows® Vista Business with downgrade to Windows® XP Professional; FreeDOS
<b>Slots</b>	1 low-profile PCI; 2 low-profile PCI Express x16; 1 low-profile PCI Express x1
<b>USB support</b>	8 x USB 2.0 ports - 2 front and 6 rear
<b>Interfaces</b>	1 x Serial port (2nd optional); 1 x Parallel port (optional)

Design and specifications are subject to change without notice. E&OE.

Version 1